

aiwa



NSX-AV320

COMPACT DISC STEREO
CASSETTE RECEIVER

- BASIC TAPE MECHANISM: 6ZM-3 PR1NM
- BASIC CD MECHANISM: 4ZG-1 Z3DSHNM

- TYPE: EZ,K

SIMPLE MANUAL

SYSTEM	CD CASSEIVER	SPEAKER	REMOTE CONTROLLER
NSX-AV320	CX-NAV320	SX-NAV304 SX-C605 SX-R275	RC - 8AS

- If requiring information about the CD mechanism, see Service Manual of 4ZG-1, S/M Code No. 09-983-249-30T.
- Replace this Service Manual with "Revision Publishing" when it is issued.

MANUAL
SERVICE

ELECTRICAL MAIN PARTS LIST - 2

REF.NO.	PARTNO.	KANRI NO	DESCRIPTION	REF.NO.	PARTNO.	KANRI NO	DESCRIPTION
C351	87-012-140-080	CAP 470P		C768	87-010-197-080	CAP, CHIP 0.01 DM	
C352	87-012-140-080	CAP 470P		C769	87-010-408-080	CAP, ELECT 47-50V	
C354	87-010-175-080	CAP 560P		C770	87-015-821-080	C-CAP 0.047	
C355	87-012-349-080	C-CAP,S 1000P-50 CH		C771	87-010-407-080	CAP, ELECT 33-50V	
C356	87-010-260-080	CAP, ELECT 47-25V		C772	87-010-194-080	CAP, CHIP 0.047	
C357	87-010-197-080	CAP, CHIP 0.01 DM		C773	87-010-196-080	CHIP CAPACITOR,0.1-25	
C358	87-010-183-080	C-CAP,S 2700P-50 B		C774	87-010-263-080	CAP, ELECT 100-10V	
C359	87-010-183-080	C-CAP,S 2700P-50 B		C775	87-010-404-080	CAP, ELECT 4.7-50V	
C360	87-010-183-080	C-CAP,S 2700P-50 B		C776	87-010-197-080	CAP, CHIP 0.01 DM	
C370	87-010-196-080	CHIP CAPACITOR,0.1-25		C777	87-010-400-080	CAP, ELECT 0.47-50V	
C373	87-016-083-080	C-CAP,S 0.15-16 RK		C778	87-010-401-080	CAP, ELECT 1-50V	
C374	87-016-083-080	C-CAP,S 0.15-16 RK		C779	87-010-401-080	CAP, ELECT 1-50V	
C378	87-010-196-080	CHIP CAPACITOR,0.1-25		C780	87-010-196-080	CHIP CAPACITOR,0.1-25	
C379	87-010-382-080	CAP, ELECT 22-25V		C781	87-010-405-080	CAP, ELECT 10-50V	
C380	87-010-382-080	CAP, ELECT 22-25V		C782	87-010-405-080	CAP, ELECT 10-50V	
C386	87-010-196-080	CHIP CAPACITOR,0.1-25		C783	87-015-819-080	CAPACITOR,0.01	
C401	87-010-405-080	CAP, ELECT 10-50V		C784	87-010-197-080	CAP, CHIP 0.01 DM	
C402	87-010-405-080	CAP, ELECT 10-50V		C785	87-010-403-080	CAP, ELECT 3.3-50V	
C457	87-010-404-080	CAP, ELECT 4.7-50V		C786	87-010-403-080	CAP, ELECT 3.3-50V	
C458	87-010-404-080	CAP, ELECT 4.7-50V		C789	87-010-188-080	CAP,CHIP 6800P	
C516	87-010-196-080	CHIP CAPACITOR,0.1-25		C790	87-010-188-080	CAP,CHIP 6800P	
C601	87-010-180-080	C-CER 1500P		C791	87-010-405-080	CAP, ELECT 10-50V	
C602	87-010-180-080	C-CER 1500P		C793	87-010-180-080	C-CAP,S 1500P<EZ>	
C613	87-010-196-080	CHIP CAPACITOR,0.1-25		C793	87-010-181-080	C-CAP,S 1800P<K>	
C614	87-010-196-080	CHIP CAPACITOR,0.1-25		C794	87-010-406-080	CAP, ELECT 22-50	
C619	87-010-185-080	C-CAP,S 3900P-50 B		C795	87-010-596-080	CAP, S 0.047-16	
C620	87-010-185-080	C-CAP,S 3900P-50 B		C796	87-010-403-080	CAP, ELECT 3.3-50V	
C621	87-010-401-080	CAP, ELECT 1-50V		C797	87-010-181-080	C-CAP,S 1800P-50 B	
C622	87-010-401-080	CAP, ELECT 1-50V		C798	87-010-181-080	C-CAP,S 1800P-50 B	
C629	87-010-405-080	CAP, ELECT 10-50V		C799	87-010-194-080	CAP, CHIP 0.047	
C630	87-010-213-080	C-CAP,S 0.015-50 B		C812	87-010-197-080	CAP, CHIP 0.01 DM	
C631	87-010-194-080	CAP, CHIP 0.047		C814	87-010-197-080	CAP, CHIP 0.01 DM	
C632	87-010-263-080	CAP, ELECT 100-10V		C820	87-010-408-080	CAP, ELECT 47-50V	
C633	87-010-263-080	CAP, ELECT 100-10V		C821	87-010-197-080	CAP, CHIP 0.01 DM	
C634	87-010-196-080	CHIP CAPACITOR,0.1-25		C822	87-010-197-080	CAP, CHIP 0.01 DM	
C635	87-010-196-080	CHIP CAPACITOR,0.1-25		C823	87-010-197-080	CAP, CHIP 0.01 DM	
C636	87-010-194-080	CAP, CHIP 0.047		C828	87-010-196-080	CHIP CAPACITOR,0.1-25	
C637	87-010-183-080	C-CAP,S 2700P-50 B		C829	87-010-196-080	CHIP CAPACITOR,0.1-25	
C641	87-010-196-080	CHIP CAPACITOR,0.1-25		C859	87-010-197-080	CAP, CHIP 0.01 DM<EZ>	
C653	87-010-318-080	C-CAP,S 47P-50 CH		C861	87-012-156-080	C-CAP,S 220P-50 CH<EZ>	
C654	87-010-318-080	C-CAP,S 47P-50 CH		C862	87-012-156-080	C-CAP,S 220P-50 CH<EZ>	
C663	87-010-322-080	C-CAP,S 100P-50 CH		C864	87-010-405-080	CAP,ELECT 10-50V<EZ>	
C664	87-010-322-080	C-CAP,S 100P-50 CH		C863	87-012-140-080	C-CAP,S 470P<EZ>	
C667	87-010-196-080	CHIP CAPACITOR,0.1-25		C865	87-010-196-080	CHIP CAPACITOR,0.1-25<EZ>	
C671	87-010-322-080	C-CAP,S 100P-50 CH		C866	87-010-405-080	CAP,ELECT 10-50V<EZ>	
C672	87-010-322-080	C-CAP,S 100P-50 CH		C867	87-010-197-080	CAP, CHIP 0.01 DM<EZ>	
C701	87-010-381-080	CAP, ELECT 330-16V		C868	87-010-316-080	C-CAP,S 33P-50 CH<EZ>	
C702	87-010-404-080	CAP, ELECT 4.7-50V		C869	87-010-314-080	C-CAP,S 22P-50 CH<EZ>	
C703	87-010-197-080	CAP, CHIP 0.01 DM		C940	87-010-197-080	CAP,CHIP 0.01 DM	
C704	87-010-197-080	CAP, CHIP 0.01 DM		C942	87-010-151-080	C-CAP,S 7P-50 CH	
C709	87-010-322-080	C-CAP,S 100P-50 CH		C947	87-010-197-080	CAP,CHIP 0.01 DM	
C711	87-010-263-080	CAP, ELECT 100-10V		C949	87-014-049-080	CAP,PP 470P-100J	
C712	87-010-196-080	CHIP CAPACITOR,0.1-25		C952	87-010-197-080	CAP,CHIP 0.01 DM	
C713	87-010-197-080	CAP, CHIP 0.01 DM		C957	87-010-311-080	C-CAP,S 12P	
C714	87-010-197-080	CAP, CHIP 0.01 DM		C958	87-010-197-080	CAP,CHIP 0.01 DM	
C715	87-010-322-080	C-CAP,S 100P-50 CH		C959	87-010-196-080	CHIP CAPACITOR,0.1-25	
C721	87-010-312-080	C-CAP,S 15P-50 CH		C960	87-010-196-080	CHIP CAPACITOR,0.1-25	
C722	87-010-312-080	C-CAP,S 15P-50 CH		C962	87-010-401-080	CAP,ELECT 1-50V	
C723	87-010-178-080	CHIP CAP 1000P		CF801	87-008-423-010	CERAMIC FILTER, SFE10.7	
C725	87-010-178-080	CHIP CAP 1000P		CF802	87-785-747-010	CF,MS2 GHY.R	
C727	87-010-196-080	CHIP CAPACITOR,0.1-25		FFE801	A8-6ZA-19C-170	6ZA-1 YFEENC	
C728	87-010-248-080	CAP, ELECT 220-10V		J201	87-A60-483-010	JACK,DIA6.3 BLK ST W/S KM	
C755	87-010-197-080	CAP, CHIP 0.01 DM		J203	87-033-240-010	TERMINAL,SP 4P32SV1-05	
C756	87-010-197-080	CAP, CHIP 0.01 DM		J212	87-A60-399-010	JACK,PIN 1P BLK HSP-241VBL<EZ>	
C757	87-010-318-080	C-CAP,S 47P-50 CH		J601	87-A60-425-010	JACK,PIN 2P YKC21-3828	
C758	87-010-149-080	C-CAP,S 5P-50 CH		J802	87-A60-427-010	TERMINAL,ANT PAL 2P YKD31-0429	
C761	87-010-196-080	CHIP CAPACITOR,0.1-25		L201	87-003-383-010	COIL,1UH-S	
C762	87-010-197-080	CAP, CHIP 0.01 DM		L202	87-003-383-010	COIL,1UH-S	
C763	87-010-194-080	CAP, CHIP 0.047		L301	87-A50-049-010	COIL,TRAP 85K(COI)	
C765	87-010-197-080	CAP, CHIP 0.01 DM		L302	87-A50-049-010	COIL,TRAP 85K(COI)	
C766	87-010-197-080	CAP, CHIP 0.01 DM		L351	87-007-342-010	COIL,OSC 85K BIAS	
C767	87-010-405-080	CAP, ELECT 10-50V		L771	87-A50-266-010	COIL,FM DET-2N(TOK)	

ELECTRICAL MAIN PARTS LIST - 3

REF.NO.	PARTNO.	KANRI NO	DESCRIPTION	REF.NO.	PARTNO.	KANRI NO	DESCRIPTION
L772	87-A90-733-010		FLTR,PCFAZH-450 (TOK)	C501	87-010-401-040		CAP,E 1-50 SME
L781	87-005-847-080		COIL,2.2UH(CECS)	C502	87-010-177-080		C-CAP,S 820P-50 SL
L832	86-NFZ-694-080		COIL,2.2UH K CECS	C504	87-010-546-040		CAP,E 0.33-50 SME
L941	87-A50-020-010		COIL,ANT LW(COI)	C505	87-010-321-080		CHIP CAPACITOR,82P(J)
L942	87-A50-019-010		COIL,OSC LW(COI)	C506	87-010-405-040		CAP,E 10-50
L981	87-NF4-651-010		COIL,AM PACK 2N(TOM)	C508	87-010-248-040		CAP,E 220-10 SME
R237	87-A00-258-080		RES,M/F 0.22-1W J	C509	87-010-545-040		CAP,E 0.22-50 SME
R238	87-A00-258-080		RES,M/F 0.22-1W J	C510	87-018-209-080		CAP,CER 0.1-50V
R239	87-A00-258-080		RES,M/F 0.22-1W J	C511	87-010-406-040		CAP,E 22-50 SME
R240	87-A00-258-080		RES,M/F 0.22-1W J	C513	87-010-405-040		CAP,E 10-50
R629	87-029-082-010		RES,FUSE 100-1/4W	C514	87-010-186-080		CAP,CHIP 4700P
SFR351	87-A90-433-080		SFR,50K H NVZ6TLTA	CON101	87-099-720-010		CONN,30P TYK-B(P)
SFR352	87-A90-433-080		SFR,50K H NVZ6TLTA	CON102	87-099-015-010		CONN,13P 6216V
TC942	87-011-221-080		CAP,TRIMMER 30P	CON301	87-099-013-010		CONN,11P 6216 V
X721	87-A70-061-010		VIB,XTAL 4.500MHZ CSA-309	CON601	87-099-016-010		CONN,14P 6216V
X851	87-A70-091-010		VIB,XTAL 4.332MHZ CSA-309<EZ>	EMI501	87-008-372-080		FILTER, EMI BL OIRNI
				FL401	88-NF8-603-010		FL,SVA-11MM12
				J501	87-A60-651-010		JACK,3.5MONO
FRONT C.B				LED208	87-070-281-080		LED,SLZ736A-25H-S-T1 P-GRN
				LED209	87-070-281-080		LED,SLZ736A-25H-S-T1 P-GRN
	88-911-091-110		FF-CABLE,11P 1.25	LED210	87-070-281-080		LED,SLZ736A-25H-S-T1 P-GRN
	88-913-321-110		FF-CABLE,13P 1.25 320MM	LED211	87-070-281-080		LED,SLZ736A-25H-S-T1 P-GRN
	88-906-251-110		FF-CABLE,6P 1.25	LED213	87-070-281-080		LED,SLZ736A-25H-S-T1 P-GRN
C36	87-010-322-080		C-CAP,S 100P-50 CH	LED222	87-070-201-080		LED,SLP9118C-51-S RED
C37	87-010-322-080		C-CAP,S 100P-50 CH	LED223	87-070-201-080		LED,SLP9118C-51-S RED
C38	87-010-322-080		C-CAP,S 100P-50 CH	LED224	87-070-201-080		LED,SLP9118C-51-S RED
C39	87-010-322-080		C-CAP,S 100P-50 CH	LED225	87-070-201-080		LED,SLP9118C-51-S RED
C40	87-010-322-080		C-CAP,S 100P-50 CH	LED226	87-070-201-080		LED,SLP9118C-51-S RED
C41	87-010-322-080		C-CAP,S 100P-50 CH	LED227	87-070-201-080		LED,SLP9118C-51-S RED
C42	87-010-322-080		C-CAP,S 100P-50 CH	LED228	87-070-201-080		LED,SLP9118C-51-S RED
C43	87-010-322-080		C-CAP,S 100P-50 CH	LED229	87-070-201-080		LED,SLP9118C-51-S RED
C44	87-010-322-080		C-CAP,S 100P-50 CH	S401	87-A90-680-080		SW,TACT KSM0612BTS
C45	87-010-322-080		C-CAP,S 100P-50 CH	S402	87-A90-680-080		SW,TACT KSM0612BTS
C46	87-012-156-080		C-CAP,S 220P-50 CH	S403	87-A90-680-080		SW,TACT KSM0612BTS
C150	87-010-196-080		CHIP CAPACITOR,0.1-25	S404	87-A90-680-080		SW,TACT KSM0612BTS
C153	87-010-196-080		CHIP CAPACITOR,0.1-25	S405	87-A90-680-080		SW,TACT KSM0612BTS
C154	87-010-196-080		CHIP CAPACITOR,0.1-25	S406	87-A90-680-080		SW,TACT KSM0612BTS
C170	87-010-194-080		CAP,CHIP 0.047	S407	87-A90-680-080		SW,TACT KSM0612BTS
C171	87-010-196-080		CHIP CAPACITOR,0.1-25	S408	87-A90-680-080		SW,TACT KSM0612BTS
C172	87-010-406-040		CAP,E 22-50 M SME	S409	87-A90-680-080		SW,TACT KSM0612BTS
C173	87-010-194-080		CAP,CHIP 0.047	S410	87-A90-680-080		SW,TACT KSM0612BTS
C201	87-018-205-080		CAP,CERA-SOL 0.022	S411	87-A90-680-080		SW,TACT KSM0612BTS
C202	87-010-198-080		CAP,CHIP 0.022	S412	87-A90-680-080		SW,TACT KSM0612BTS
C203	87-010-198-080		CAP,CHIP 0.022	S413	87-A90-680-080		SW,TACT KSM0612BTS
C204	87-012-140-080		CAP 470P	S414	87-A90-680-080		SW,TACT KSM0612BTS
C205	87-010-316-080		C-CAP,S 33P-50 CH	S415	87-A90-680-080		SW,TACT KSM0612BTS
C206	87-010-318-080		C-CAP,S 47P-50 CH	S416	87-A90-680-080		SW,TACT KSM0612BTS
C207	87-010-312-080		C-CAP,S 15P-50 CH	S417	87-A90-680-080		SW,TACT KSM0612BTS
C208	87-010-196-080		CHIP CAPACITOR,0.1-25	S418	87-A90-680-080		SW,TACT KSM0612BTS
C209	87-010-494-040		CAP,E 1-50 GAS	S419	87-A90-680-080		SW,TACT KSM0612BTS
C210	87-A10-189-040		CAP,E 220-10	S420	87-A90-680-080		SW,TACT KSM0612BTS
C211	87-010-194-080		CAP,CHIP 0.047	S421	87-A90-680-080		SW,TACT KSM0612BTS
C212	87-010-555-040		CAP,E 100-10 GAS	S423	87-A90-680-080		SW,TACT KSM0612BTS
C213	87-010-196-080		CHIP CAPACITOR,0.1-25	S424	87-A90-680-080		SW,TACT KSM0612BTS<EZ>
C214	87-010-405-040		CAP,E 10-50	S425	87-A90-680-080		SW,TACT KSM0612BTS
C215	87-012-156-080		C-CAP,S 220P-50 CH	S426	87-A90-680-080		SW,TACT KSM0612BTS<EZ>
C216	87-012-156-080		C-CAP,S 220P-50 CH	S428	87-A90-680-080		SW,TACT KSM0612BTS<EZ>
C217	87-010-197-080		CAP,CHIP 0.01 DM	SW201	87-A90-535-010		SW,RTRY EC16B24304
C250	87-010-196-080		CHIP CAPACITOR,0.1-25	SW202	88-NF8-615-010		SW,RTRY EC16B24204L=25
C270	87-010-196-080		CHIP CAPACITOR,0.1-25	X201	87-A70-075-080		VIB,CER 4.19MHZ CRHF
C307	87-015-686-040		CAP,E 22-25 M 7L SRA				
C354	87-010-196-080		CHIP CAPACITOR,0.1-25	PRO C.B			
C355	87-010-196-080		CHIP CAPACITOR,0.1-25	C101	87-012-368-080		C-CAP,S 0.1-50 Z F
C373	87-010-196-080		CHIP CAPACITOR,0.1-25	C102	87-012-368-080		C-CAP,S 0.1-50 Z F
C376	87-012-158-080		C-CAP,S 390P-50 CH	C103	87-016-051-090		CAP,E 2200-35 M SMG
C378	87-010-196-080		CHIP CAPACITOR,0.1-25	C104	87-016-051-090		CAP,E 2200-35 M SMG
C401	87-010-405-040		CAP,E 10-50	C105	87-010-196-080		C-CAP,S 0.1-25 Z F
C402	87-010-405-040		CAP,E 10-50	C106	87-010-196-080		C-CAP,S 0.1-25 Z F
C404	87-010-194-080		CAP,CHIP 0.047	C109	87-010-188-080		C-CAP,S 6800P-50B
C405	87-010-246-040		CAP,E 47-35 SME	C112	87-012-368-080		C-CAP,S 0.1-50 Z F
C406	87-010-197-080		CAP,CHIP 0.01 DM	C113	87-012-368-080		C-CAP,S 0.1-50 Z F
C410	87-010-560-040		CAP,E 10-50 GAS	C207	87-010-545-080		CAP,E 0.22-50 M SME
C411	87-010-560-040		CAP,E 10-50 GAS				

ELECTRICAL MAIN PARTS LIST - 4

REF.NO.	PARTNO.	KANRI NO	DESCRIPTION	REF.NO.	PARTNO.	KANRI NO	DESCRIPTION
C209	87-010-180-080		C-CAP,S 1500P-50 K B	L201	87-003-383-010		COIL,1UH K
C211	87-010-404-080		CAP,E 4.7-50 M SME	L301	87-003-383-010		COIL,1UH K
C215	87-A10-596-080		C-CAP,S 100P-100 J CH	R243	87-A00-258-080		RES,M/F 0.22-1W J
C217	87-010-406-080		CAP,E 22-50 M SME	R245	87-A00-258-080		RES,M/F 0.22-1W J
C219	87-A10-596-080		C-CAP,S 100P-100 J CH	R343	87-A00-258-080		RES,M/F 0.22-1W J
C221	87-A10-899-080		CAP,E 47-25 M BP	R345	87-A00-258-080		RES,M/F 0.22-1W J
C223	87-010-544-080		CAP,E 0.1-50 M SME	R509	87-022-214-080		C-RES,S 100K-1/10W F
C225	87-010-993-080		C-CAP,S 0.056-25 K B				
C227	87-010-196-080		C-CAP,S 0.1-25 Z F				
C229	87-A10-799-080		C-CAP,S 5600P-16 J B	AC1 C.B			
C230	87-A10-799-080		C-CAP,S 5600P-16 J B	F101	87-035-455-010		FUSE,2A 250V T W/C
C233	87-010-263-080		CAP,E 100-10 SME	FC101	87-A90-505-080		FUSE CLAMP,TP00351-51
C234	87-010-235-080		CAP,E 470-16 SME	FC102	87-A90-505-080		FUSE CLAMP,TP00351-51
C307	87-010-545-080		CAP,E 0.22-50 M SME	PT101	88-NFV-608-010		PT,8NF-28E
C309	87-010-181-080		C-CAP, 1800P-50 K B	T101	87-A60-317-010		TERMINAL, 1P MSC
C311	87-010-404-080		CAP,E 4.7-50 M SME	T102	87-A60-317-010		TERMINAL, 1P MSC
C315	87-A10-596-080		C-CAP,S 100P-100 J CH				
C317	87-010-408-080		CAP,E 47-50 M SME	AC2 C.B			
C319	87-A10-596-080		C-CAP,S 100P-100 J CH				
C321	87-A10-899-080		CAP,E 47-25 M BP	PR101	87-026-682-080		PROTECTOR,10A 491 SERIES 60V
C323	87-010-544-080		CAP,E 0.1-50 M SME	PR102	87-026-682-080		PROTECTOR,10A 491 SERIES 60V
C325	87-010-993-080		C-CAP,S 0.056-25 K B	PR105	87-A90-195-080		PROTECTOR,7A 491 SERIES 60V
C327	87-010-196-080		C-CAP,S 0.1-25 Z F	PR106	87-A90-195-080		PROTECTOR,7A 491 SERIES 60V
C333	87-010-263-080		CAP,E 100-10 SME	W104	85-NF5-628-010		F-CABLE 7P-2.5
C501	87-010-176-080		C-CAP,S 680P-50 J SL				
C502	87-010-176-080		C-CAP,S 680P-50 J SL	DECK C.B			
C503	87-A10-804-080		C-CAP,S 0.1-25 J B	CON105	87-099-753-019		CONN,11P H 9604
C504	87-A10-804-080		C-CAP,S 0.1-25 J B	CON301	86-ZM3-604-219		CON ASSY,3P-PB
C505	87-A10-804-080		C-CAP,S 0.1-25 J B	CON351	86-ZM3-605-119		CON ASSY,8P-RPB
C506	87-A10-804-080		C-CAP,S 0.1-25 J B	SFR1	87-024-581-089		SFR,3.3K DIA 6H
C509	87-010-112-080		CAP,E 100-16 M SME	SOL1	82-ZM1-618-410		SOL ASSY,27
C510	87-010-221-080		CAP,E 470-10 M SME	SOL2	82-ZM1-618-410		SOL ASSY,27
C511	87-A10-891-080		CAP,E 4.7-25 SME(K)	SW1	87-A90-248-010		SW,MICRO ESE11SH2CX0
C512	87-A10-800-080		C-CAP,S 6800P-16 J B	SW2	87-A90-248-010		SW,MICRO ESE11SH2CX0
C513	87-010-374-080		CAP,E 47-10 M SME	SW3	87-A90-248-010		SW,MICRO ESE11SH2CX0
C514	87-010-196-080		C-CAP,S 0.1-25 Z F	SW4	87-A90-248-010		SW,MICRO ESE11SH2CX0
C515	87-010-400-080		CAP,E 0.47-50 M SME	SW5	87-A90-248-010		SW,MICRO ESE11SH2CX0
C516	87-010-400-080		CAP,E 0.47-50 M SME	W1	82-ZM3-601-019		RBN-CORD,4P-75
C519	87-010-544-080		CAP,E 0.1-50 M SME				
C520	87-010-546-080		CAP,E 0.33-50 SME				
C522	87-018-209-080		CAP,TC U 0.1-50 Z F				
C523	87-A10-804-080		C-CAP,S 0.1-25 J B				
C524	87-010-374-080		CAP,E 47-10 M SME				
C526	87-010-196-080		C-CAP,S 0.1-25 Z F				
C530	87-010-544-080		CAP,E 0.1-50 M SME				
C531	87-010-546-080		CAP,E 0.33-50 SME				
C532	87-010-971-080		C-CAP,S 4700P-50 J B				
C533	87-012-349-080		C-CAP,S 1000P-50 J CH				
C538	87-010-971-080		C-CAP,S 4700P-50 J B				
C539	87-012-349-080		C-CAP,S 1000P-50 J CH				
C540	87-010-401-080		CAP,E 1-50 M SME				
C541	87-010-401-080		CAP,E 1-50 M SME				
C542	87-A10-799-080		C-CAP,S 5600P-16 J B				
C543	87-A10-802-080		C-CAP,S 0.047-16 J B				
C544	87-A10-229-080		C-CAP,S 0.68-10 K				
C545	87-012-393-080		C-CAP,S 0.22-16 K				
C546	87-012-393-080		C-CAP,S 0.22-16 K				
C547	87-010-404-080		CAP,E 4.7-50 M SME				
C548	87-010-404-080		CAP,E 4.7-50 M SME				
C549	87-012-393-080		C-CAP,S 0.22-16 K				
C550	87-012-393-080		C-CAP,S 0.22-16 K				
C551	87-016-081-080		C-CAP,S 0.1-16 K R				
C552	87-A10-802-080		C-CAP,S 0.047-16 J B				
C553	87-A10-802-080		C-CAP,S 0.047-16 J B				
C554	87-016-081-080		C-CAP,S 0.1-16 K R				
C555	87-016-081-080		C-CAP,S 0.1-16 K R				
C556	87-A10-801-080		C-CAP,S 0.022-16 J B				
C557	87-A10-801-080		C-CAP,S 0.022-16 J B				
C558	87-016-081-080		C-CAP,S 0.1-16 K R				
C579	87-010-402-080		CAP,E 2.2-50 M SME				
C580	87-010-402-080		CAP,E 2.2-50 M SME				
C581	87-010-196-080		C-CAP,S 0.1-25 Z F				

MECHANICAL PARTS LIST - 1

NOTE: The characters in the suffix column indicate the part usage.

VKSEXX.....	A.....
VEZEXX.....	B.....
AKSEXX.....	C.....
AEZEXX.....	D.....
6EZEXX.....	E.....

REF.NO	PARTS NO.	KANRI NO.	DESCRIPTION	SUFFIX
	86-NFZ-001-010		WINDOW, TOP	ABCDE.....
	87-NB8-005-010		PANEL, LEFT	ABCDE.....
	87-NB8-009-010		WINDOW, CD
	87-NB8-012-010		WINDOW, CASS 1
	87-NB8-013-010		WINDOW, CASS 2
	87-NB8-051-010		PANEL, LEFT U
	87-NF9-055-010		PANEL, TOP	ABCDE.....
	88-NF8-043-010		BOX, CASS 2 1WAY
	88-NF8-044-010		BOX, CASS 1 1WAY
	88-NF8-046-010		PANEL, TRAY	ABCDE.....
	88-NF8-047-010		PANEL, RIGHT 2	ABCDE.....
	88-NF8-048-010		PANEL, RIGHT 2 U
	88-NFV-001-010		CABI, FR U
	88-NFV-003-010		CABI, FR E AV320
	88-NFV-004-010		CABI, FR K
	88-NFV-011-010		WINDOW, DISPLAY U
	88-NFV-013-010		WINDOW, DISPLAY E AV320
	88-NFV-014-010		WINDOW, DISPLAY K
	88-NFV-021-010		CABI, REAR USTNM MT320
	88-NFV-024-010		CABI, REAR EZSTNE AV320	.B.D.....
	88-NFV-025-010		CABI, REAR KSTNE	A.C.....
	88-NFV-026-010		CABI, REAR VJSTNM
	88-NFV-027-010		CABI, REAR EZSTNE AV326E.....
	88-NFV-028-010		CABI, REAR EZSTNM AV320
	87-NB8-015-010		KNOB, RTRY VOL
	88-NF8-006-210		KEY, REC
	88-NF8-007-010		KEY, FUNCTION
	88-NF8-013-010		KEY, ASSY FF
	88-NF8-014-110		KEY, CD
	88-NF8-015-110		KEY, RDS
	88-NF8-016-010		KNOB, RTRY JOG
	88-NF8-019-010		KEY, PLAY 1WAY ASSY
	88-NFV-006-010		KEY, PRO
	88-NFV-007-010		KEY, GEQ PRO
	81-532-080-010		LABEL, CASS. COMPT
	88-NFV-010-010		PLATE, PRO
	88-NF8-616-010		CONN ASSY, 8P RPBE.....
	84-ZG1-245-210		CAP, OPTICAL	ABCDE.....
	82-NF5-218-010		SPR-T, EJECT 1 (SIN)	ABCDE.....
	82-NF5-219-010		SPR-T, EJECT 2 (SIN)	ABCDE.....
	82-NF5-229-010		PLATE, LOCK
	86-NF9-224-010		SPR-C, LOCK
	87-064-185-010		HLDR, WIRE	ABCDE.....
	87-NF4-216-010		HLDR, LOCK 1
	87-NF4-217-010		HLDR, LOCK 2
	87-NF4-221-010		HLDR, CABLE	ABCDE.....
	87-NF8-220-010		DMPR, 150
	88-NF5-208-010		HLDR, PWB-M N	ABCDE.....
	87-067-579-010		TAPPING SCREW, BVT2+3-8	ABCDE.....
	87-067-641-010		UTT2+3-8(W/O SLOT)BL	ABCDE.....
	87-067-688-010		BVTT+3-6	ABCDE.....
	87-067-703-010		TAPPING SCREW, BVT2+3-10	ABCDE.....
	87-078-019-010		S-SCREW, IT+4-6	ABCDE.....
	87-721-096-410		QT2+3-10 GLD	ABCDE.....
	87-721-097-410		QT2+3-12 GLD	ABCDE.....
	87-723-096-410		QT2+3-10W/O SLOT BL	ABCDE.....
	87-NF4-224-010		S-SCREW, IT3B+3-8 CU	ABCDE.....
	87-003-317-010		F-BEAD, F0H2515-LG7	..CDE.....
	87-010-402-010		CAP, ELECT 2.2-50SME	AB.....
	87-050-034-010		AC CORD ASSY, E	.B.DE.....
	87-050-053-010		AC CORD ASSY, U-2
	87-050-079-010		AC-CORD ASSY, E
	87-085-185-010		BUSHING, AC CORD (E)	ABCDE.....
	87-085-189-010		BUSHING, CORD (U)
	87-A80-023-010		AC CORD, ASSY K 3P W	A.C.....
	88-906-251-110		FF-CABLE, 6P 1.25	ABCDE.....
	88-911-091-110		FF-CABLE, 11P 1.25
	88-913-321-110		FF-CABLE, 13P 1.25 320MM
	88-914-141-110		FF-CABLE, 14P 1.25
C	218	87-018-209-080	CAP, CER 0.1-50V
C	800	87-018-109-080	CAP, CER 22P-50V	..D.....
C	801	87-018-109-080	CAP, CER 22P-50V	..D.....
F	101	87-035-223-010	FUSE, 1.25AT	AB.....
F	101	87-035-416-010	FUSE, T3A 250V UL
F	101	87-035-455-010	FUSE 2A250V T W/C	..CDE.....
PT	101	88-NFV-604-010	PT, 8NF-28U
PT	101	88-NFV-608-010	PT, 8NF-28E	ABCDE.....
		88-NF8-205-010	GUIDE, FL
		88-NF8-207-010	GUIDE, FF	ABCDE.....
		88-NF8-208-010	GUIDE, PLAY 1WAY
		88-NFV-201-010	GUIDE, PRO
W	104	85-NF5-628-010	F-CABLE 7P-2.5	ABCDE.....

MECHANICAL PARTS LIST - 2

WH	101	87-A90-460-010	HLDR,WIRE 2.5-7P	ABCDE.....
		87-067-703-010	TAPPING SCREW, BVT2+3-10	ABCDE.....
WH	102	87-A90-460-010	HLDR,WIRE 2.5-7P	ABCDE.....

MECHANISM PARTS LIST - 1

REF.NO.	PARTNO.	KANRI NO	DESCRIPTION	REF.NO.	PARTNO.	KANRI NO	DESCRIPTION
1	86-ZM3-212-010		CHAS ASSY,SS				
2	86-ZM3-202-010		BASE,HEAD S	26	82-ZM1-243-019		LVR,STOP
3	86-ZM3-205-010		SPR-C,RPH S	27	82-ZM1-344-119		LVR ASSY,PINCH
4	82-ZM1-333-210		PLATE,LINK 2	28	86-ZM3-204-010		SPR-T,PINCHDS
5	86-ZM3-206-010		SPR-C,EH S	29	82-ZM1-240-119		LVR,REC (DECK 2)
				30	86-ZM3-210-010		BELT,PS
6	87-A90-403-019		HEAD,RPH MS15R				
7	86-ZM3-201-010		CHAS,HEAD S	31	82-ZM1-223-010		GEAR,PLAY
8	87-045-347-019		MOT,SHU2L 70(M1)	32	82-ZM3-305-019		GEAR,CAM M2
9	82-ZM1-269-219		SPR-T,BRG	33	82-ZM1-227-319		LVR,TRIG
10	82-ZM3-323-119		SPR-T,LINK	34	82-ZM3-306-110		LVR,FR M2
				35	82-ZM1-265-119		SPR-E,TRIG
11	86-ZM3-209-010		S-SCREW,ASIMUTHS				
12	86-ZM3-207-010		S-SCREW,RPH	36	85-ZM3-203-019		S-SCREW MOTOR M3
13	87-A90-404-019		HEAD,EH LE15B	37	82-ZM1-236-019		CAPSTAN N 2-41.5
14	86-ZM3-208-010		S-SCREW,EH	37	82-ZM1-239-019		CAPSTAN N 2.2-41.7
15	86-ZM3-203-010		HLDR,MOTS	38	82-ZM1-322-019		SPR-T,FR60
				39	82-ZM1-220-219		GEAR,IDLER
16	82-ZM1-245-210		HLDR,IC				
17	82-ZM1-218-019		SPR-E,HB	40	82-ZM3-616-019		RING MAGNET 4
18	86-ZM3-211-010		BELT,RS	41	82-ZM1-216-319		GEAR,REEL
19	82-ZM1-222-219		LVR,PLAY	42	85-ZM3-213-010		S-SCREW,HLDR MOT 3
20	82-ZM1-217-419		REEL,TABLE	43	82-ZM1-225-219		GEAR,FR
				44	82-ZM1-226-019		GEAR,REW
21	82-ZM1-244-519		SPR-C,BT				
22	82-ZM1-285-410		SPR-C,BT L	45	82-ZM3-333-210		SLIP DISK ASSY 2
23	82-ZM1-257-019		SPR-T,CAS	46	82-ZM1-338-010		BELT FR4
24	82-ZM3-221-010		PULLEY,MOT 2M	47	82-ZM1-349-019		FLY-WHL RW (DECK L)
25	82-ZM1-242-019		LE=VR,CAS	47	82-ZM3-331-019		FLY-WHL R2W (DECK R)
				A	87-251-071-417		U+2.6-4
				B	80-ZM6-243-019		SH,1.75-3.6-0.5 SLT

ACCESSORIES / PACKAGE LIST- 1

NOTE: The characters in the suffix column indicate the part usage.

VKSEXX.....	A.....
VEZEXX.....	B.....
AKSEXX.....	C.....
AEZEXX.....	D.....
6EZEXX.....	E.....

REF.NO	PARTS NO.	KANRI NO.	DESCRIPTION	SUFFIX
	88-NFV-903-110		IB,U(ESF)M
	88-NFV-905-010		IB,K(E)E	A.C.....
	88-NFV-906-010		IB,E(9L)E	.B.D.....
	88-NFV-907-010		IB,V(ER)M
	88-NFV-916-010		IB,E(6L)E 326E.....
	88-NFV-926-010		IB,E(9L)M
	87-006-225-010		AM LOOP ANT NC2	ABCDE.....
	87-043-106-010		WIRE, FM ANT (Z)	ABCDE.....
	87-043-115-010		ANT,FEEDER FM
	88-NFV-605-010		RC UNIT,RC-8AS04	ABCDE.....

SCHEMATIC DIAGRAM – 4 (PRO)

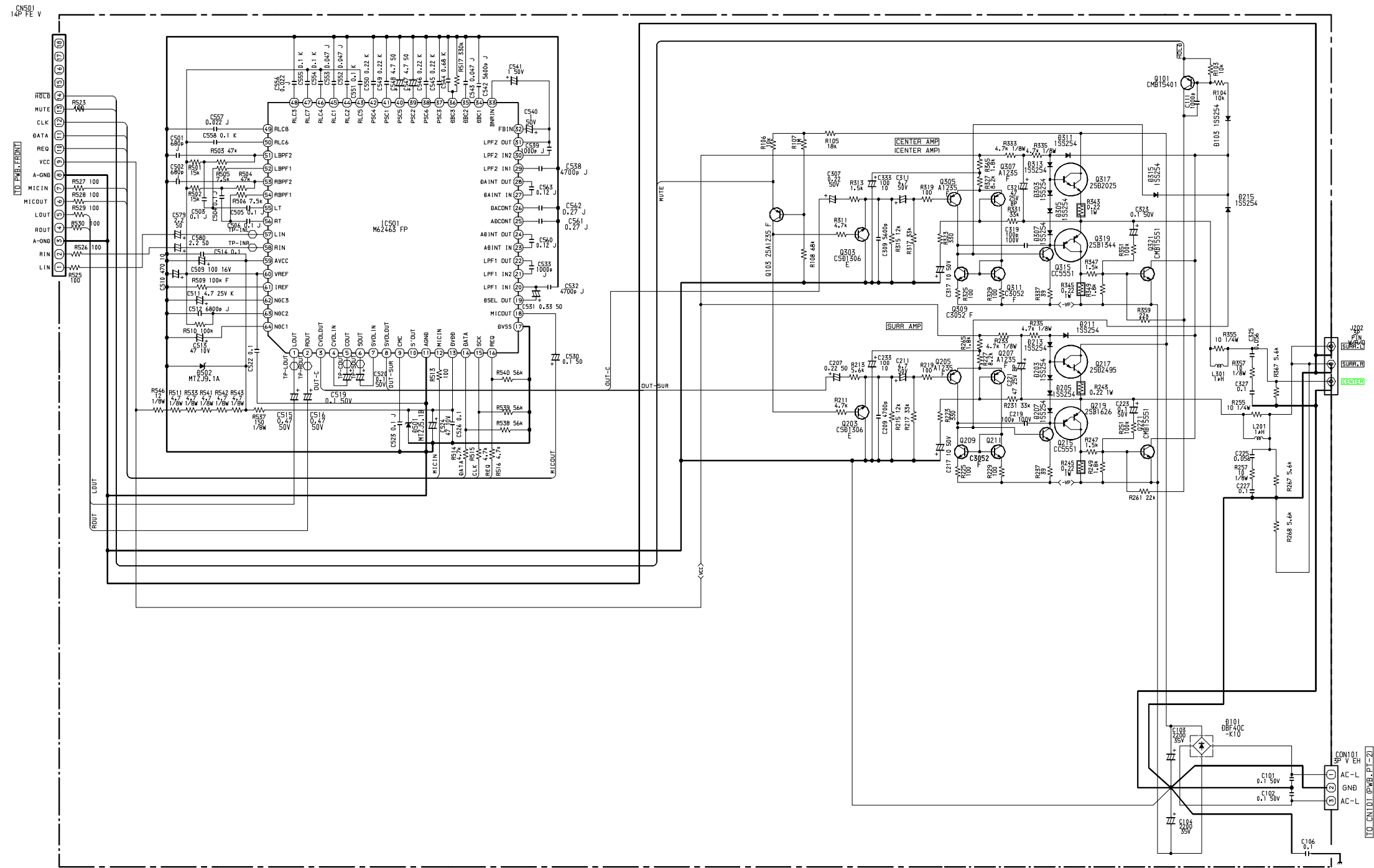

B-8NF-28-PRO

T:SHIMIZU-SHINDU
 @PRO-LOGIC
 SCHEMATIC DIAGRAM
 QC-88ZA4
 8ZA-4
 8ZA-4 PRDM
 16 FEB 1998

SCHEMATIC DIAGRAM - 5 (AC)

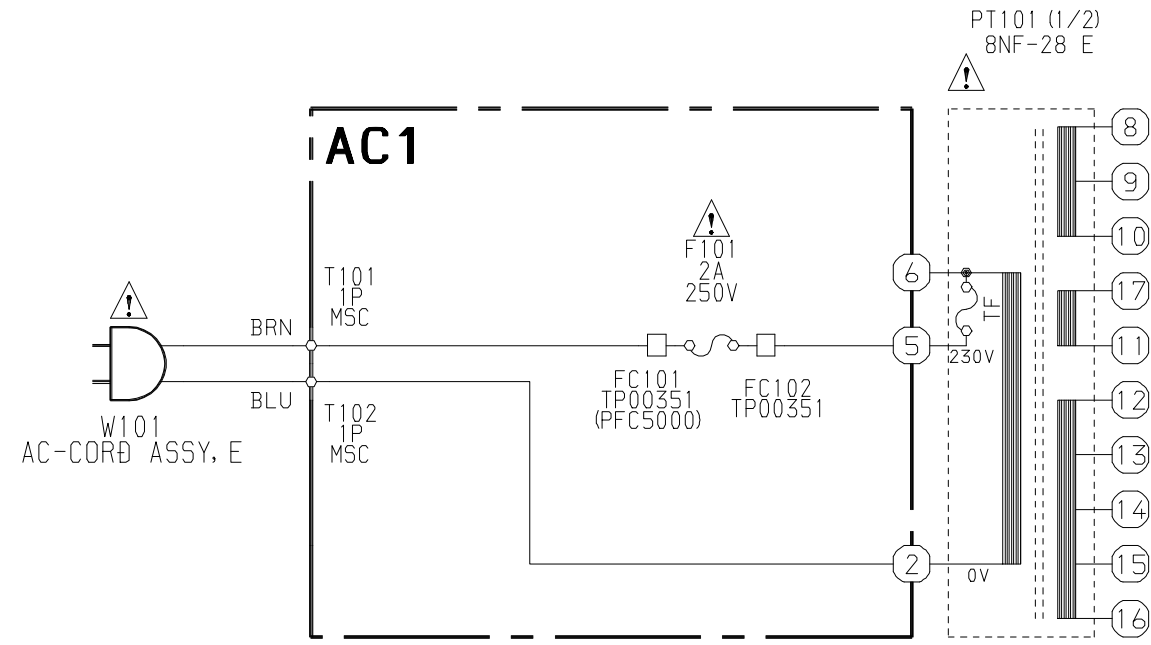

加藤 小松

(PT1)
SCHEMATIC DIAGRAM

(EZ) WITH RDS
8NF-28

QC-88NFV

CX-NAV320

06TH APR 1998

B-8NF-28MAIN-EZ-RDS (P2)

サービス技術ニュース	
番号	連絡内容
G- -	
G- -	
G- -	

アイワ株式会社
AIWA CO.,LTD.

9620450,750038

Tokyo Japan